



-
-
-
-



				MANITOU	MANITOU
				ES614	ES616
		Q	kg	1400	1600
		c	mm	600	600
		x	mm	687	687
		y	mm	1250	1250
			kg	870	874
			kg	1037 / 1453	1064 / 1624
			kg	851 / 240	851 / 244
			mm	1x(Ø230x70)	1x(Ø230x70)
			mm	2x(Ø82x68)	2x(Ø82x68)
			mm	1x(Ø140x60)	1x(Ø140x60)
				1x1 / 4	1x1 / 4
		b10	mm	529	529
		b11	mm	380	380
		h1	mm	1930	1930
		h2		-	-
		h3		2935*	2935*
		h4		3374	3374
		h5		-	-
		h14	mm	750 / 1250	750 / 1250
		h13	mm	85 ^{-0 +5}	85 ^{-0 +5}
		l1	mm	1910 ¹	1910 ¹
		l2	mm	761	761
		b1	mm	800	800
		s / e / l	mm	60 x 185 x 1150	60 x 185 x 1150
		b3		700	700
		b5	mm	565	565
		m1		-	-
		m2	mm	30	30
		Ast		2464 ¹	2464 ¹
		Ast	mm	2438 ¹	2438 ¹
		Wa	mm	1588 ¹	1588 ¹
			km/h	6 / 6	6 / 6
			m/s	0,16 / 0,3	0,14 / 0,3
			m/s	0,28 / 0,22	0,29 / 0,22
			%	7 / 10	7 / 10
			kW	1,5	1,5
			kW	3	3
				DIN 43535-B	DIN 43535-B
			V/Ah	24/180 - 300 (375)	24/180 - 300 (375)
			kg	160 - 250 (325)	160 - 250 (325)
			db (A)	65	65

				MANITOU	MANITOU	MANITOU
				ES612 LI	ES614 LI	ES616 LI
		Q	kg	1200	1400	1600
		c	mm	600	600	600
		x	mm	855 / 815	848 / 808	848 / 808
		y	mm	1492 / 1452	1492 / 1452	1492 / 1452
			kg	1251	1283	1283
			kg	-	1037 / 1453	1064 / 1620
			kg	973 / 278	851 / 240	851 / 240
			mm	1x(Ø230x70)	1x(Ø230x70)	1x(Ø230x70)
			mm	2x(Ø82x68)	2x(Ø82x68)	2x(Ø82x68)
			mm	1x(Ø140x60)	1x(Ø140x60)	1x(Ø140x60)
				1x1 / 4	1x1 / 4	1x1 / 4
		b10	mm	529	529	529
		b11	mm	380	380	380
		h1	mm	1953	1953	1953
		h2		-	-	-
		h3		2935	2935*	2935*
		h4		3390	3390	3390
		h5		110	110	110
		h14	mm	750 / 1250	750 / 1250	750 / 1250
		h13	mm	84 ^{-0 +5}	86 ^{-0 +5}	86 ^{-0 +5}
		l1	mm	2024	2035**	2035**
		l2	mm	834	846**	846**
		b1	mm	800	800	800
		s / e / l	mm	60 x 185 x 1190	60 x 185 x 1190	60 x 185 x 1190
		b3		700	700	700
		b5	mm	565	565	565
		m1		-	-	-
		m2	mm	30	30	30
		Ast		2653	2653**	2653**
		Ast	mm	2587	2567**	2567**
		Wa	mm	1834	1834**	1834**
			km/h	6 / 6	6 / 6	6 / 6
			m/s	0,18 / 0,3	0,16 / 0,3	0,14 / 0,3
			m/s	0,27 / 0,22	0,28 / 0,22	0,29 / 0,22
			%	7 / 10	7 / 10	7 / 10
			kW	1,5	1,5	1,5
			kW	3	3	3
				DIN 43535-B	DIN 43535-B	DIN 43535-B
			V/Ah	24/180 - 300	24/180 - 300 (375**)	24/180 - 300 (375**)
			kg	160 - 250	160 - 250 (325)	160 - 250 (325)
			db (A)	65	65	65

*
**

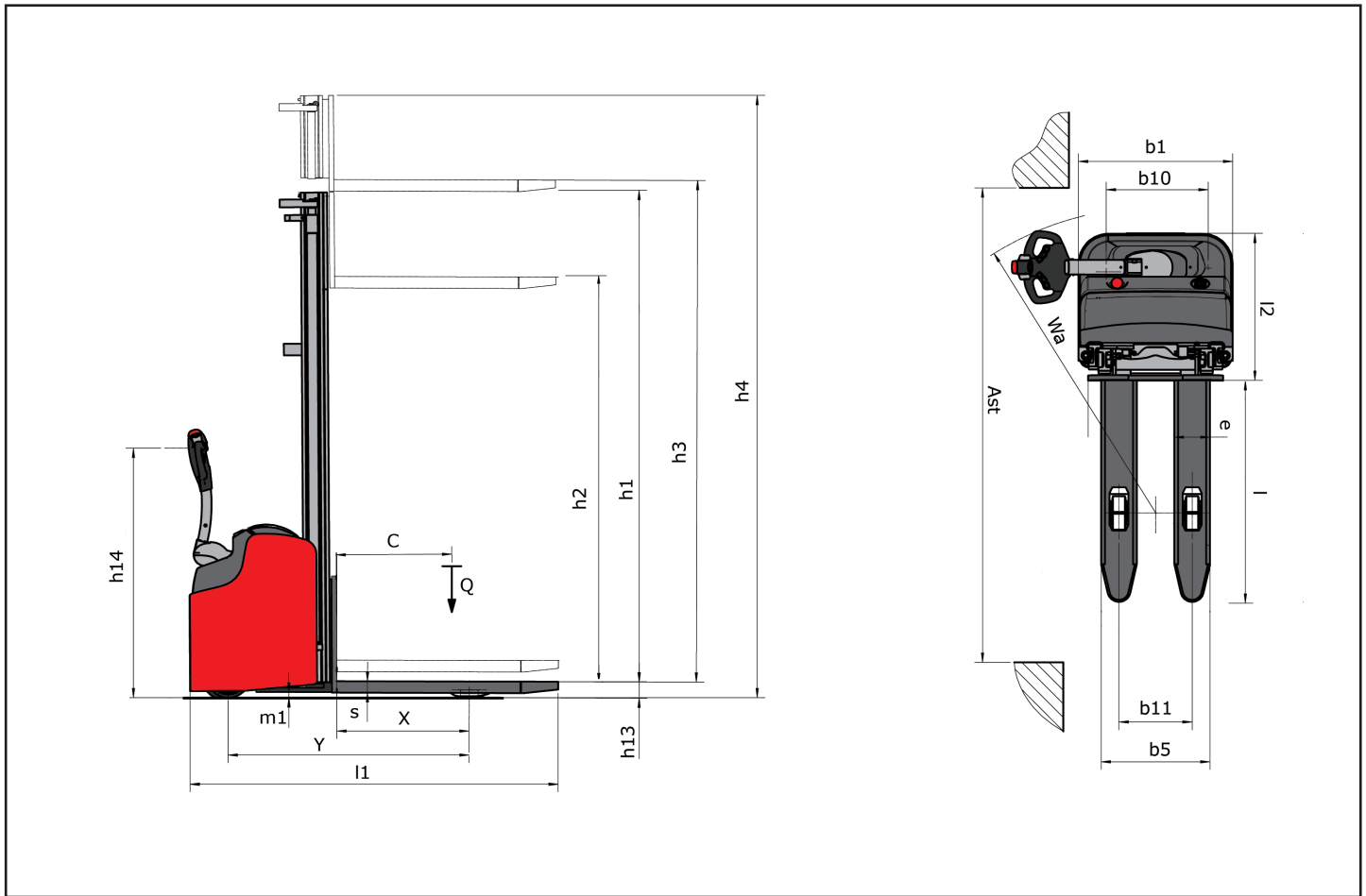

ES 612 LI			S15	S17							
					DVC29	DVC34	DVC38	DLL 29	DLL34	TLL42	TLL45
h3		mm	1506	1756	2936	3436	3836	2931	3431	4246	4726
h1		mm	1953	2203	1953	2203	2403	1953	2203	1911	2071
h2		mm	1506	1756	-	-	-	1506	1756	1466	1626
h4		mm	1960	2210	3390	3890	4290	3385	3885	4723	5203

ES 614 LI - ES 616 LI			S15	S17								
					D29	D34	D38	DLL 29	DLL 34	TLL42	TLL47	TLL54 ¹
h3		mm	1506	1756	2936	3436	3836	2931	3431	4226	4726	5455
h1		mm	1953	2203	1953	2203	2403	1953	2203	1911	2071	2300
h2		mm	1506	1756	-	-	-	1506	1756	1466	1626	1875
h4		mm	1960	2210	3390	3890	4290	3385	3885	4723	5203	5880

				MANITOU	MANITOU	MANITOU
				ES612 LI PFR	ES614 LI PFR***	ES616 LI PFR***
		Q	kg	1200	1400	1600
		c	mm	600	600	600
		x	mm	855 / 815	848 / 808	848 / 808
		y	mm	1492 / 1452	1492 / 1452	1492 / 1452
			kg	1251	1283	1283
			kg	1133 / 1318	1189 / 1493	1216 / 1660
			kg	973 / 278	1003 / 280	1003 / 280
			mm	1x(Ø230x70)	1x(Ø230x70)	1x(Ø230x70)
			mm	2x(Ø82x68)	2x(Ø82x68)	2x(Ø82x68)
			mm	1x(Ø140x60)	1x(Ø140x60)	1x(Ø140x60)
				1x1 / 4	1x1 / 4	1x1 / 4
		b10	mm	529	529	529
		b11	mm	380	380	380
		h1	mm	1953	1953	1953
		h2		-	-	-
		h3		2935	2935*	2935*
		h4		3390	3390	3390
		h5		110	110	110
		h14	mm	993 / 1203	993 / 1203	993 / 1203
		h13	mm	84 ⁻⁰⁺⁵	86 ⁻⁰⁺⁵	86 ⁻⁰⁺⁵
		l1	mm	2162 / 2587	2174 / 2599 ¹	2174 / 2599 ¹
		l2	mm	973 / 1398	984 / 1409 ¹	984 / 1409 ¹
		b1	mm	800	800	800
		s / e / l	mm	60 x 185 x 1190	60 x 185 x 1190	60 x 185 x 1190
		b3		700	700	700
		b5	mm	565	565	565
		m1		-	-	-
		m2	mm	30	30	30
		Ast		2490 / 2914	2672 / 3097 ¹	2672 / 3097 ¹
		Ast	mm	2464 / 2888	2587 / 3012 ¹	2587 / 3012 ¹
		Wa	mm	1614 / 2038	1852 / 2277 ¹	1852 / 2277 ¹
			km/h	6 / 6	6 / 6	6 / 6
			m/s	0,18 / 0,3	0,16 / 0,3	0,14 / 0,3
			m/s	0,27 / 0,22	0,28 / 0,22	0,29 / 0,22
			%	7 / 10	7 / 10	7 / 10
			kW	1,5	1,5	1,5
			kW	3	3	3
				DIN 43535-B	DIN 43535-B	DIN 43535-B
			V/Ah	24/180 - 300	24/180 - 300 (375)	24/180 - 300 (375)
			kg	160 - 250	160 - 250 (325)	160 - 250 (325)
			db (A)	65	65	65

*
**

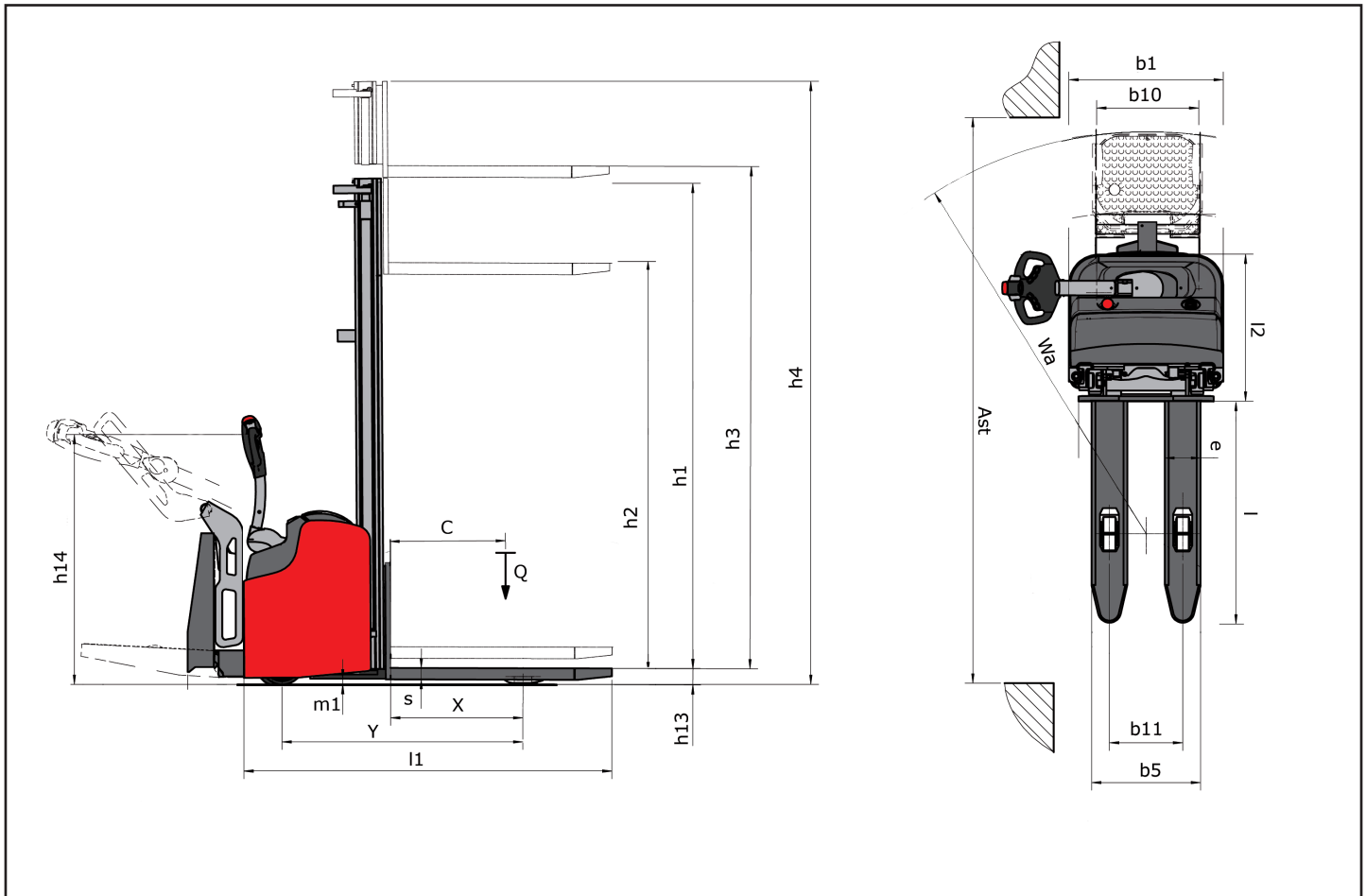

ES 612 LI			S15	S17	DVC29	DVC34	DVC38	DLL 29	DLL34	TLL42	TLL45
			h3	mm	1506	1756	2936	3436	3836	2931	3431
h1	mm	1953	2203	1953	2203	2403	1953	2203	1911	2071	
h2	mm	1506	1756	-	-	-	1506	1756	1466	1626	
h4	mm	1960	2210	3390	3890	4290	3385	3885	4723	5203	

ES 614 LI - ES 616 LI			S15	S17	D29	D34	D38	DLL 29	DLL 34	TLL42	TLL47	TLL54 ¹
			h3	mm	1506	1756	2936	3436	3836	2931	3431	4226
h1	mm	1953	2203	1953	2203	2403	1953	2203	1911	2071	2300	
h2	mm	1506	1756	-	-	-	1506	1756	1466	1626	1875	
h4	mm	1960	2210	3390	3890	4290	3385	3885	4723	5203	5880	

